

**SESSION ONE**

**SYSTEM APPROACH TO BIOGAS TECHNOLOGY**

## SESSION ONE

### System Approach To Biogas Technology

#### 1.1 Introduction

A system is a conglomerate of interrelated parts, each of which in turn can be viewed as a subsystem {Flippo, 1981). This training takes a system approach to understand various aspects of biogas technology and its relevance to other sectors at different levels of operation. Chart 1.1 shows inner and extended systems of the biogas technology. It depicts various subsystems through which biogas could be affected and influence the socio-economic well-being of a society. Such an understanding is necessary for being able to manipulate different elements of the biogas system to make optimum use of the technology in different situations.

This is the first session of the training programme and by the end of this session, the participants will be able to:

- explain different components of biogas technology;
- explain relevance of multi-disciplinary approach for promotion of the technology; explain inter-relationships between biogas and other subsystems that surround it; and
- enumerate critical factors to consider in making optimum use of the technology in a given situation or context.

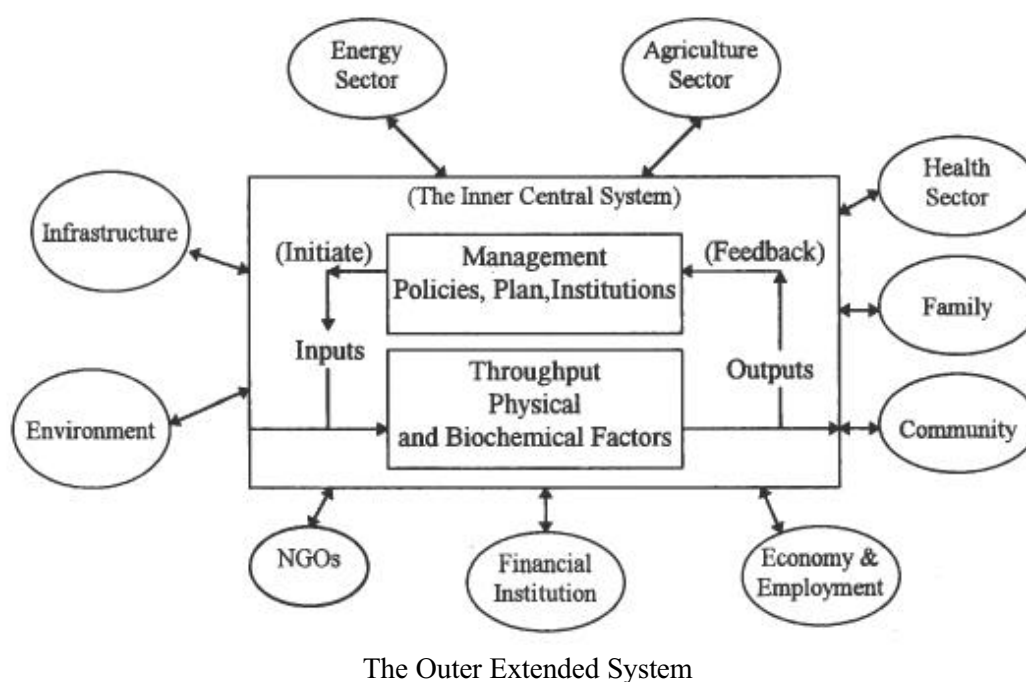

**Chart 1.1 A System Approach to Biogas Technology**

#### 1.2 Components of a Biogas System

Biogas technology is a complete system in itself with its set objectives (cost effective production of energy and soil nutrients), factors such as microbes, plant design, construction materials, climate, chemical and microbial characteristics of inputs, and the inter-relationships among these factors. Brief discussions on each of these factors or subsystems are presented in this section.

### 1.2.1 Biogas

This is the mixture of gas produced by methanogenic bacteria while acting upon biodegradable materials in an anaerobic condition. Biogas is mainly composed of 50 to 70 percent methane, 30 to 40 percent carbon dioxide (CO<sub>2</sub>) and low amount of other gases as shown in Table 1.1.

Table 1.1  
Composition of Biogas

Substances	Symbol	Percentage
Methane	CH <sub>4</sub>	50 - 70
Carbon Dioxide	CO <sub>2</sub>	30-40
Hydrogen	H <sub>2</sub>	5- 10
Nitrogen	N <sub>2</sub>	1-2
Water vapour	H <sub>2</sub> O	0.3
Hydrogen Sulphide	H <sub>2</sub> S	Traces

Sources: Yadav and Hesse 1981

Biogas is about 20 percent lighter than air and has an ignition temperature in the range of 650° to 750° C. It is an odourless and colourless gas that burns with clear blue flame similar to that of LPG gas (Sathianathan, 1975). Its calorific value is 20 Mega Joules (MJ) per m<sup>3</sup> and burns with 60 percent efficiency in a conventional biogas stove.

### 1.2.2 Methanogenic Bacteria or Methanogens

These are the bacteria that act upon organic materials and produce methane and other gases in the process of completing their life-cycle in an anaerobic condition. As living organisms, they tend to prefer certain conditions and are sensitive to micro-climate within the digester. There are many species of methanogens and their characteristics vary.

The different methane forming bacteria have many physiological properties in common, but they are heterogeneous in cellular morphology. Some are rods, some cocci, while others occur in clusters of cocci known as sarcinae. The family of methanogens (Methanobacteriaceae) is divided into following four genera on the basis of cytological differences (Alexander, 1961).

#### A. Rod-shaped Bacteria

- (a) Non-sporulating, Methanobacterium
- (b) Sporulating, Methanobacillus

#### B. Spherical

- (a) Sarcinae, Methanosarcina
- (b) Not in sarcinal groups, Methanococcus

A considerable level of scientific knowledge and skill is required to isolate methanogenic bacteria in pure culture and maintain them in a laboratory. Methanogenic bacteria develop slowly and are sensitive to a sudden change in physical and chemical conditions. For example, a sudden fall in the slurry temperature by even 1°C may significantly affect their growth and gas production rate (Lagrange, 1979).

### 1.2.3 Biodigester

The biodigester is a physical structure, commonly known as the biogas plant. Since various chemical and microbiological reactions take place in the biodigester, it is also known as bio-reactor or anaerobic reactor. The main function of this structure is to provide anaerobic condition within it. As a chamber, it should be air and water tight. It can be made of various construction materials and in different shape and size. Construction of this structure forms a major part of the investment cost. Some of the commonly used designs are discussed below.

#### *Floating Drum Digester*

Experiment on biogas technology in India began in 1937. In 1956, Jashu Bhai J Patel developed a design of floating drum biogas plant popularly known as *Gobar Gas plant*. In 1962, Patcl's design was approved by the Khadi and Village Industries Commission (KVIC) of India and this design soon became popular in India and the world. The design of KVIC plant is shown in Figure 1.1.

In this design, the digester chamber is made of brick masonry in cement mortar. A mild steel drum is placed on top of the digester to collect the biogas produced from the digester. Thus, there are two separate structures for gas production and collection. With the introduction of fixed dome Chinese model plant, the floating drum plants became obsolete because of comparatively high investment and maintenance cost along with other design weaknesses. In Nepal, KVIC design plants have not been constructed since 1986.

#### *Fixed Dome Digester*

Fixed dome Chinese model biogas plant (also called drumless digester) was built in China as early as 1936. It consists of an underground brick masonry compartment (fermentation chamber) with a dome on the top for gas storage. In this design, the fermentation chamber and gas holder are combined as one unit. This design eliminates the use of costlier mild steel gas holder which is susceptible to corrosion. The life of fixed dome type plant is longer (from 20 to 50 years) compared to KVIC plant. Based on the principles of fixed dome model from China, Gobar Gas and Agricultural Equipment Development Company (GGC) of Nepal has developed a design and has been popularizing it since the last 17 years. The concrete dome is the main characteristic of GGC design. Its sketch is given in Figure 1.2.

#### *Deenbandhu Model*

In an effort to further bring down the investment cost, Deenbandhu model was put forth in 1984 by the Action for Food Production (AFPRO), New Delhi. In India, this model proved 30 percent cheaper than Janata Model (also developed in India) which is the first fixed dome plant based on Chinese technology. It also proved to be about 45 percent cheaper than a KVIC plant of comparable size. Deenbandhu plants are made entirely of brick masonry work with a spherical shaped gas holder at the top and a concave bottom. A typical design of Deenbandhu plant is shown in Figure 1.3 (Singh, Myles and Dhussa, 1987).

The Soudi Asian Partnership/Nepal (SAP/N), an INGO working in Nepal, has introduced Deenbandhu model plants in Bardiya district of Nepal. About 100 plants were constructed by SAP/N in the villages of Bardiya district in 1994. Preliminary studies carried out by BSP did not find any significant difference in the investment costs of GGC and the Deenbandhu design plants.

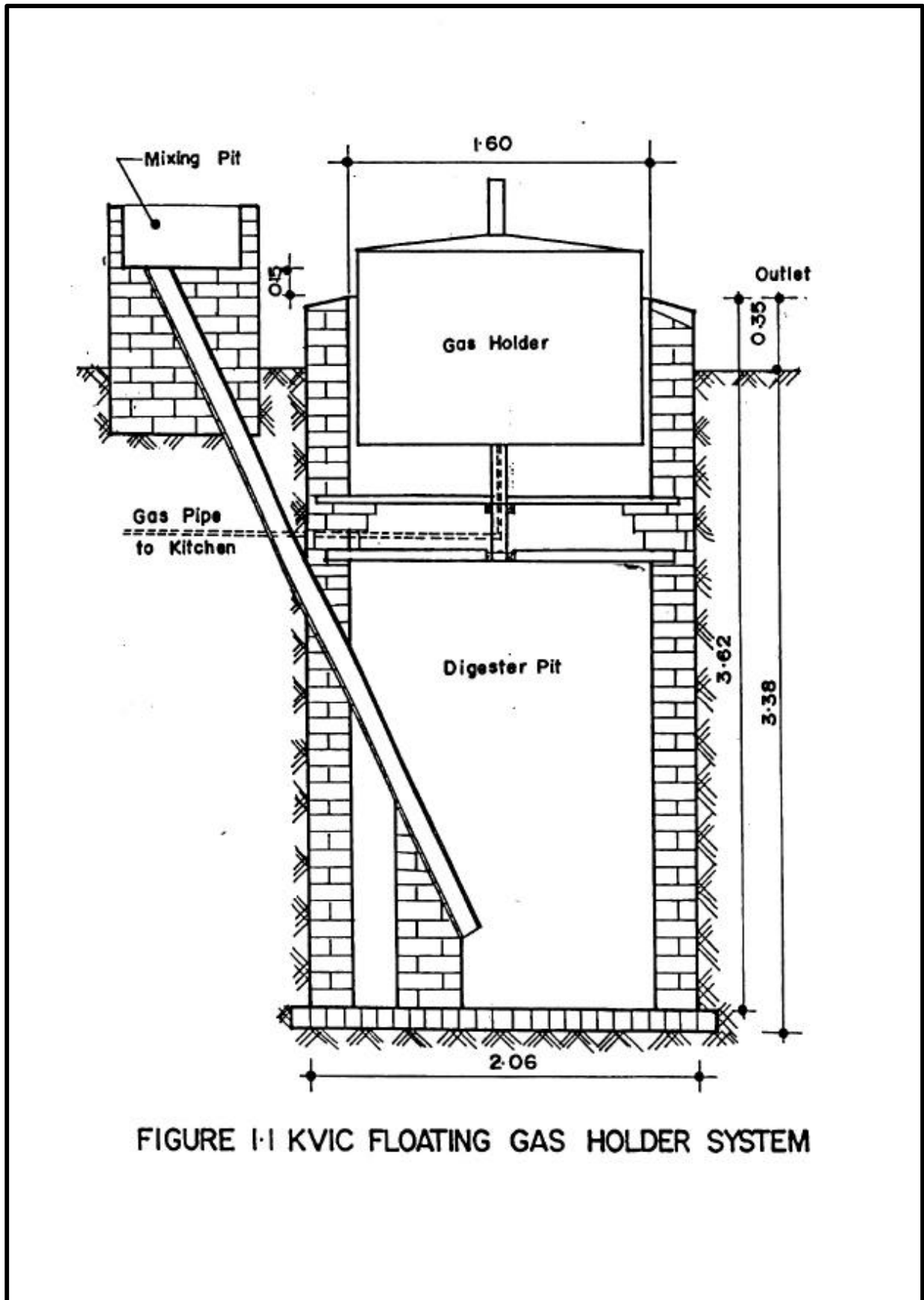
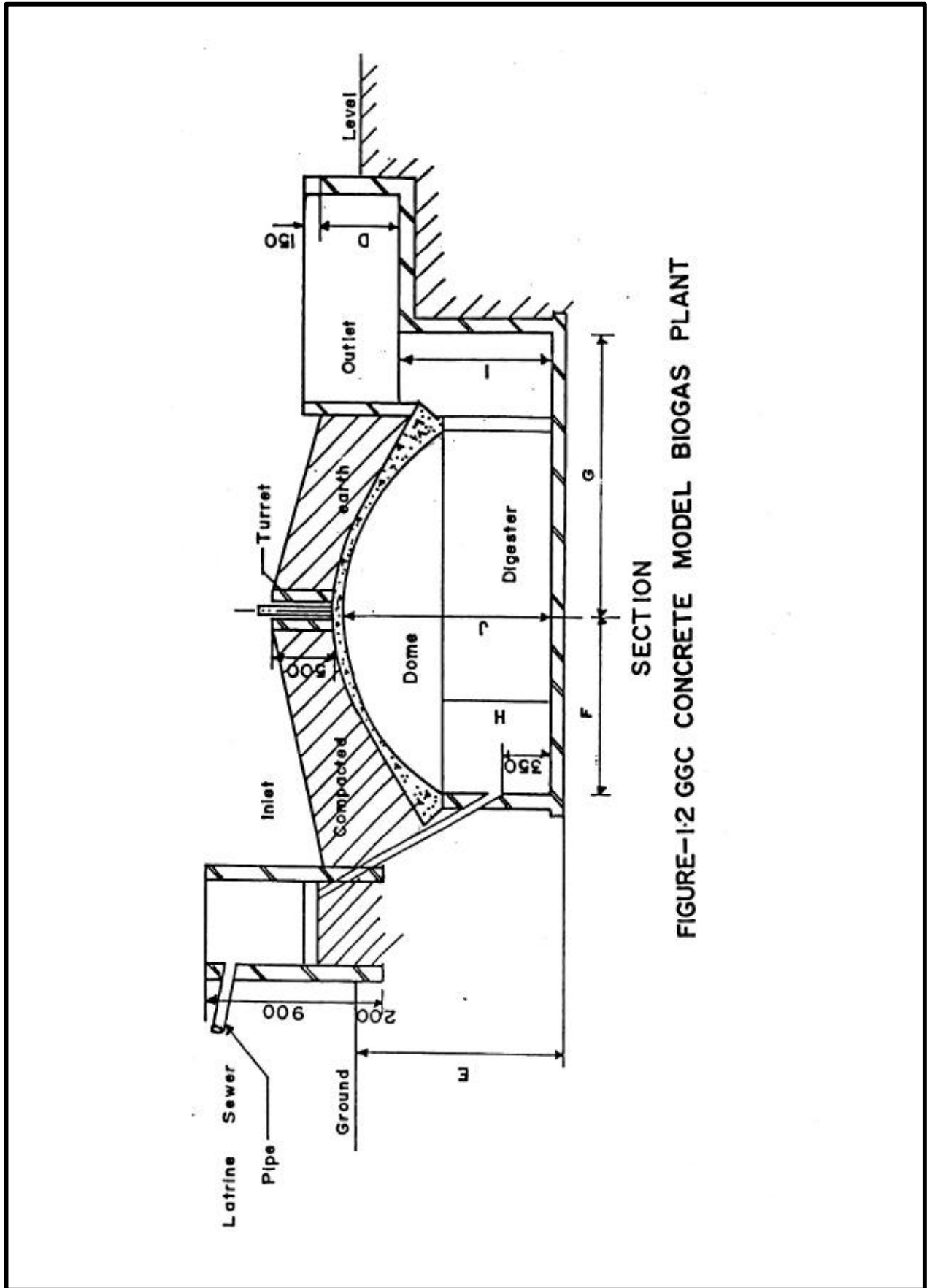

FIGURE 1.1 KVIC FLOATING GAS HOLDER SYSTEM



SECTION  
FIGURE-1:2 GGC CONCRETE MODEL BIOGAS PLANT

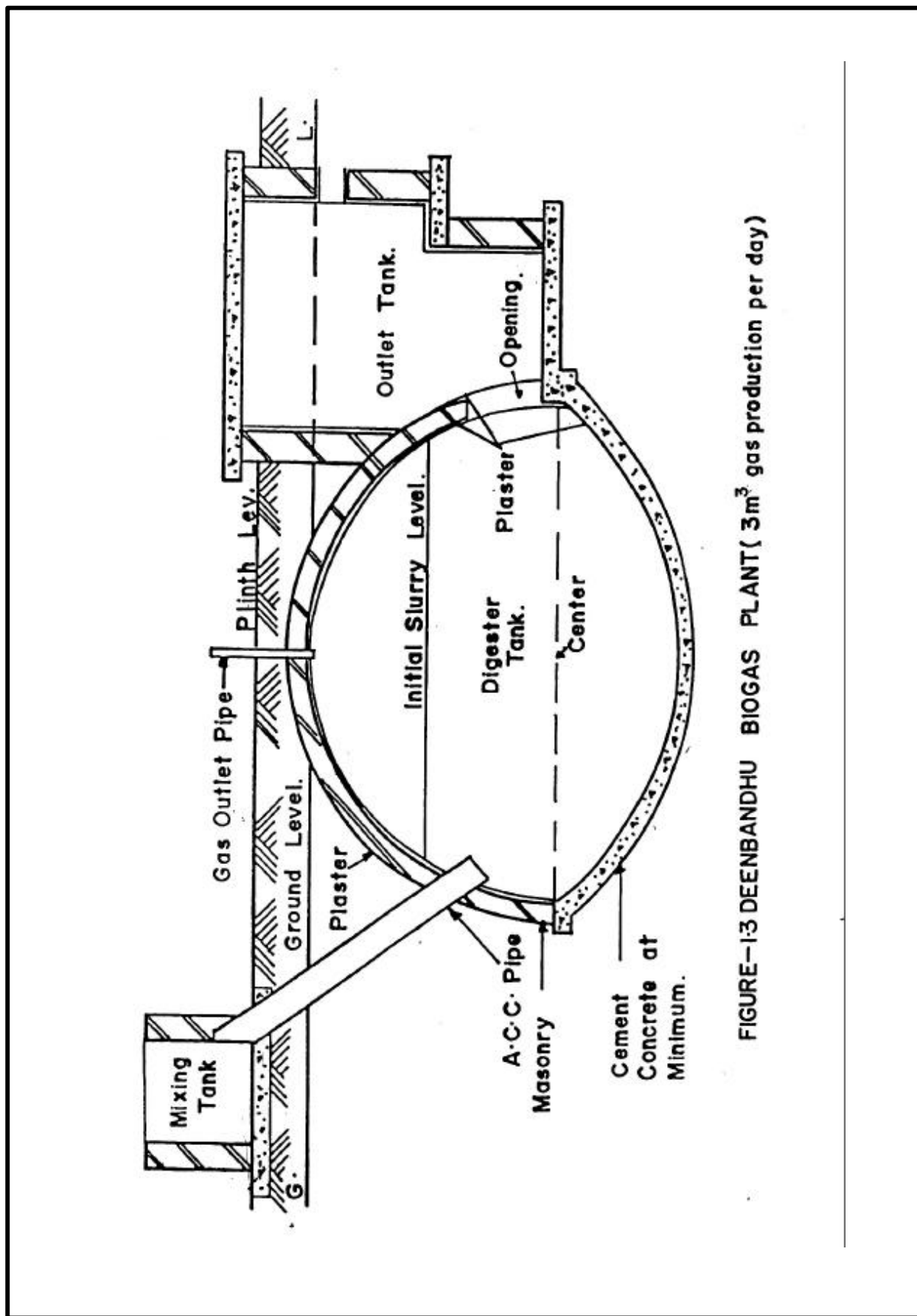

FIGURE-13 DEENBANDHU BIOGAS PLANT (3m<sup>3</sup> gas production per day)

Recently, Environmental Protection and Social Development Association (EPA), a NGO, has constructed modified Deenbandhu design plants in Bardiya district which is also approved by Biogas Support Programme (BSP)

In addition to above designs developed particularly for household use in developing countries, there are other designs suitable for adoption in other specific conditions. Though they are not of much relevance to present conditions in Nepal, they could prove useful in the future. These designs are briefly described below for reference.

#### *Bag Digester*

This design was developed in 1960s in Taiwan. It consists of a long cylinder made of PVC or red mud plastic (Figure 1.4). The bag digester was developed to solve the problems experienced with brick and metal digesters. A PVC bag digester was also tested in Nepal by GGC at Butwal from April to June 1986. The study concluded that the plastic bag biodigester could be successful only if PVC bag is easily available, pressure inside the digester is increased and welding facilities are easily available (Biogas Newsletter, No. 23, 1986). Such conditions are difficult to meet in most of the rural areas in developing countries.

#### *Plug Flow Digester*

The plug flow digester is similar to the bag digester. It consists of a trench (trench length has to be considerably greater than the width and depth) lined with, concrete or an impermeable membrane. The reactor is covered with either a flexible cover gas holder anchored to the ground, concrete or galvanized iron (GI) top. The first documented use of this type of design was in South Africa in 1957. Figure 1.5 shows a sketch of such a reactor (Gunnerson and Stuckey, 1986). This design has not been constructed at the field level in Nepal.

#### *Anaerobic Filter*

This type of digester was developed in the 1950's to use relatively dilute and soluble waste water with low level of suspended solids. It is one of the earliest and simplest type of design developed to reduce the reactor volume. It consists of a column filled with a packing medium. A great variety of non-biodegradable materials have been used as packing media for anaerobic filter reactors such as stones, plastic, coral, mussel shells, reeds, and bamboo rings. The methane forming bacteria form a film on the large surface of the packing medium and are not washed out of the digester with the effluent. For this reason, these reactors are also known as "fixed film" or "retained film" digesters (Bioenergy Systems Report, 1984). Figure 1.6 presents a sketch of the anaerobic filter (Gunnerson and Stuckey, 1986). This design is best suited for treating industrial, chemical and brewery wastes.

#### *Upflow Anaerobic Sludge Blanket*

This UASB design was developed in 1980 in the Netherlands. It is similar to the anaerobic filter in that it involves a high concentration of immobilized bacteria in the reactor. However, the UASB reactors contain no packing medium, instead, the methane forming bacteria are concentrated in the dense granules of sludge blanket which covers the lower part of the reactor. The feed liquid enters from the bottom of the reactor and biogas is produced while liquid flows up through the sludge blanket (Figure 1.7). Many full-scale UASB plants are in operation in Europe using waste water from sugar beet processing and other dilute wastes that contain mainly soluble carbohydrates (Bioenergy Systems Report, 1984). Such reactor has not been experimented in Nepal.



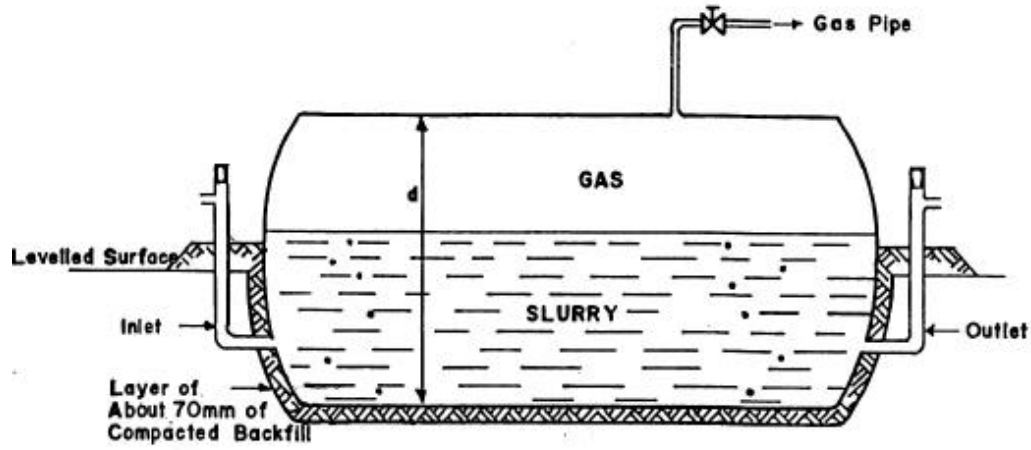

FIGURE 1.4 BAG DIGESTER.

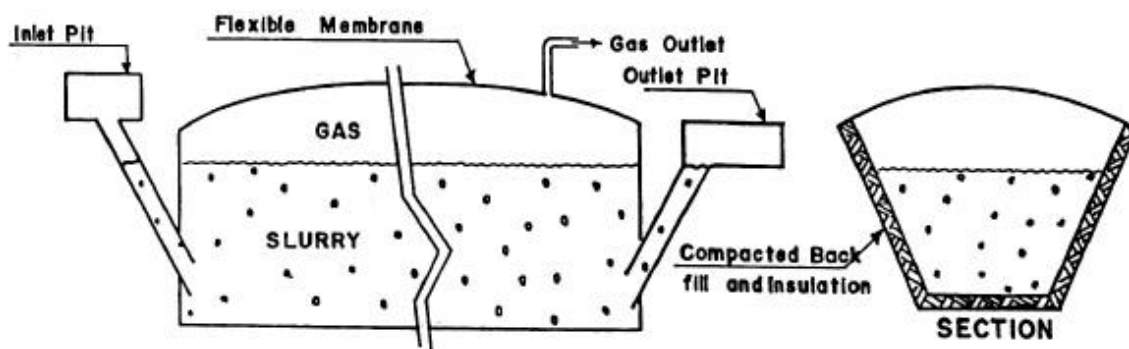

FIGURE 1.5 PLUG FLOW DIGESTER

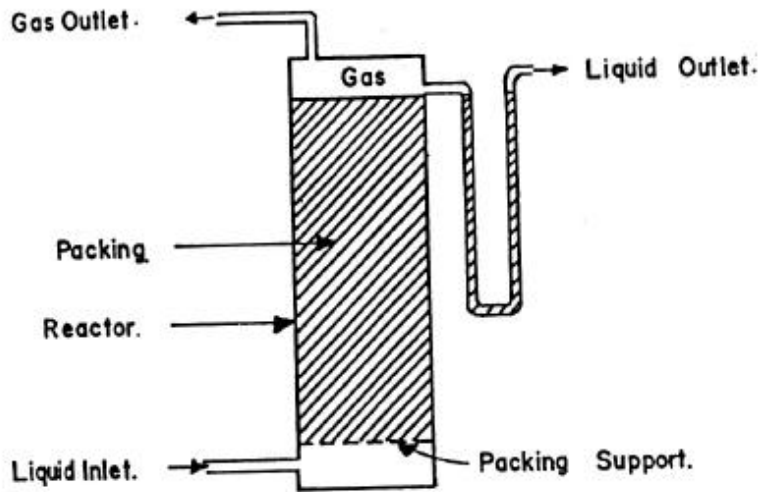

FIGURE-1:6 ANAEROBIC FILTER.

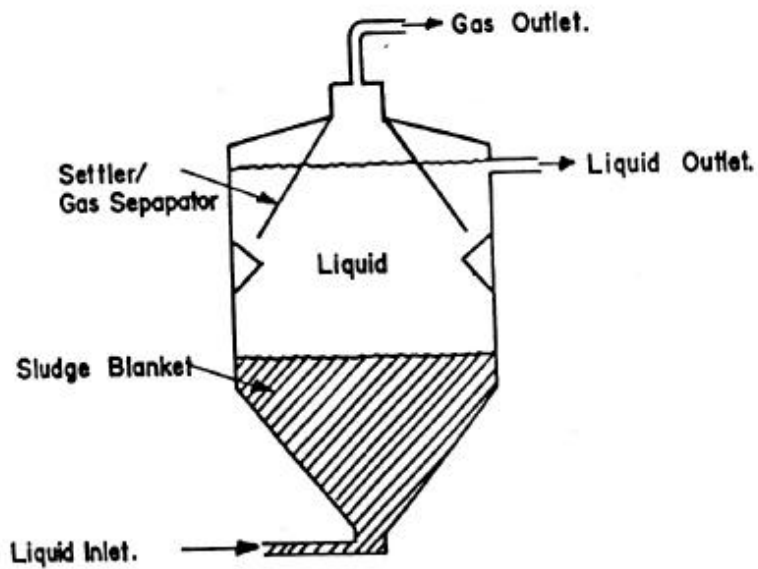

FIGURE-1:7 UPFLOW ANAEROBIC SLUDGE BLANKET(UASB)

There are also other designs of anaerobic reactors which are of less interest in the context of Nepal due to their limited utility. Reduction in investment cost using alternative construction materials has been one of the main driving forces in the development of new designs. In an effort to achieve this objective, use of bamboo, plastics and other such cheap construction materials have also been tried with varying degree of success (Cortsen, Lassen and Neilsen, 1995; Beteta, 1995). However, all such reported success stories are yet to take the form of implementation programmes on a mass scale.

The main factors that influence the selection of a particular design or model of a biogas plant are as follows:

**Economic:** An ideal plant should be as low-cost as possible (in terms of the production cost per unit volume of biogas) both to the user as well as to the society. At present, with subsidy, the cost of a plant to the society is higher than to an individual user.

**Utilization of Local Materials:** Use of easily available local materials should be emphasized in the construction of a biogas plant. This is an important consideration, particularly in the context of Nepal where transportation system is not yet adequately developed.

**Durability:** Construction of a biogas plant requires certain degree of specialized skill which may not be easily available. A plant of short life could also be cost effective but such a plant may not be reconstructed once its useful life ends. Especially in situations where people are yet to be motivated for the adoption of this technology and the necessary skill and materials are not readily available, it is necessary to construct plants that are more durable although this may require a higher initial investment.

**Suitable for the Type of Inputs:** The design should be compatible with the type of inputs that would be used. If plant materials such as rice straw, maize straw or similar agricultural wastes are to be used then the batch feeding design or discontinuous system should be used instead of a design for continuous or semi-continuous feeding.

Frequency of Using inputs and Outputs: Selection of a particular design and size of its various components also depend on how frequently the user can feed the system and utilize the gas.

#### 1.2.4 Inputs and Their Characteristics

Any biodegradable organic material can be used as inputs for processing inside the biogas digester. However, for economic and technical reasons, some materials are more preferred as inputs than others. If the inputs are costly or have to be purchased, then the economic benefits of outputs such as gas and slurry will become low. Also, if easily available biodegradable wastes are used as inputs, then that benefit could be of two folds: (a) economic value of biogas and its slurry; and (b) environmental cost avoided in dealing with the biodegradable waste in some other ways such as disposal in landfill.

One of the main attractions of biogas technology is its ability to generate biogas out of organic wastes that are abundant and freely available. In case of Nepal, it is the cattle dung that is most commonly used as an input mainly because of its viability. The potential gas production from some animal dung is given in Table 1.2

**Table 1.2**  
**Gas Production Potential of Various Types of Dung**

Types of Dung	Gas Production Per Kg Dung (m <sup>3</sup> )
Cattle (cows and buffaloes)	0.023 - 0.040
Pig	0.040 - 0.059
Poultry (Ciuckens)	0.065-0.116
Human	0.020- 0.028

Source: Updated Guidebook on Biogas Development, 1984

In addition to the animal and human wastes, plant materials can also be used to produce biogas and bio-manure. For example, one kg of pre-treated crop waste and water hyacinth have the potential of producing 0.037 and 0.045 m<sup>3</sup> of biogas, respectively.

Since different organic materials have different bio-chemical characteristics, their potential for gas production also varies. Two or more of such materials can be used together provided that some basic requirements for gas production or for normal growth of methanogens are met. Some characteristics of these inputs which have significant impact on the level of gas production are described below.

**C/N Ratio :** The relationship between the amount of carbon and nitrogen present in organic materials is expressed in terms of the Carbon/Nitrogen (C/N) ratio. A C/N ratio ranging from 20 to 30 is considered optimum for anaerobic digestion. If the C/N ratio is very high, the nitrogen will be consumed rapidly by methanogens for meeting their protein requirements and will no longer react on the left over carbon content of the material. As a result, gas production will be low. On the other hand, if the C/N ratio is very low, nitrogen will be liberated and accumulated in the form of ammonia (NH<sub>4</sub>), NH<sub>4</sub> will increase the pH value of the content in the digester. A pH higher than 8.5 will start showing toxic effect on methanogen population.

Animal waste, particularly cattle dung, has an average C/N ratio of about 24. The plant materials such as straw and sawdust contain a higher percentage of carbon. The human excreta has a C/N ratio as low as 8. C/N ratio of some of the commonly used materials are presented in Table 1.3 (Karki and Dixit, 1984).

**Table 1.3**  
**C/N Ratio of Some Organic Materials**

S.N.	Raw Materials	C/N Ratio
1.	Duck dung	8
2.	Human excreta	8
3.	Chicken dung	10
4.	Goat dung	12
5.	Pig dung	18
6.	Sheep dung	19
7.	Cow dung/ Buffalo dung	24
8.	Water hyacinth	25
9.	Elephant dung	43
10.	Straw (maize)	60
11.	Straw (rice)	70
12.	Straw (wheat)	90
13.	Saw dust	above 200

Materials with high C/N ratio could be mixed with those of low C/N ratio to bring the average ratio of the composite input to a desirable level. In China, as a means to balance C/N ratio, it is customary' to load nee straw at the bottom of the digester upon which latrine waste is discharged. Similarly, at Machan Wildlife Resort located in Chitawan district of Nepal, feeding the digester with elephant dung in conjunction with human waste enabled to balance C/N ratio for smooth production of biogas (Karki, Gautam and Karki, 1994).

**Dilution and Consistency of Inputs:** Before feeding the digester, the excreta, especially fresh cattle dung, has to be mixed with water at the ratio of 1:1 on a unit volume basis (i.e. same volume of water for a given volume of dung) However, if the dung is in dry form, the quantity of water has to be increased accordingly to arrive at the desired consistency of the inputs (e.g. ratio could vary from 1:1.25 to even 1:2). The dilution should be made to maintain the total solids from 7 to 10 percent. If the dung is too diluted, the solid particles will settle down into the digester and if it is too thick, the particles impede the flow of gas formed at the lower part of digester. In both cases, gas production will be less than optimum. A survey made by BSP reveals that the farmers often over dilute the slum'.

For thorough mixing of the cow dung and water (slurry), GGC has devised a Slurry Mixture Machine that can be fitted in the inlet of a digester. The specifications of the Slurry Mixture Machine which presently costs Rs 625 is given in Figure 1.8. It is also necessary to remove inert materials such as stones from the inlet before feeding the slurry into the digester Otherwise, the effective volume of the digester will decrease.

**Volatile Solids :** The weight of organic solids burned off when heated to about 538" C is defined as volatile solids. The biogas production potential of different organic materials, given in Table 1.2, can also be calculated on the basis of their volatile solid content. The higher the volatile solid content in a unit volume of fresh dung, the higher the gas production For example, a kg of volatile solids in cow dung would yield about 0.25 m<sup>3</sup> biogas (Sathianathan. 1975).

### 1.2.5 Digestion

Digestion refers to various reactions and interactions that take place among the methanogens. non-methanogens and substrates fed into the digester as inputs. This is a complex physio-chemical and biological process involving different factors and stages of change. This process of digestion (methanization) is summarized below in its simple form.

The breaking down of inputs that are complex organic materials is achieved through three stages as described below:

*Stage 1 Hydrolysis:* The waste materials of plant and animal origins consist mainly of carbohydrates, lipids, proteins and inorganic materials. Large molecular complex substances are solubilized into simpler ones with the help of extracellular enzyme released by the bacteria. This stage is also known as polymer breakdown stage. For example, the cellulose consisting of polymerized glucose is broken down to dimeric, and then to monomeric sugar molecules (glucose) by cellulolytic bacteria.

*Stage 2 Acidification:* The monomer such as glucose which is produced in Stage 1 is fermented under anaerobic condition into various acids with the help of enzymes produced by the acid forming bacteria. At this stage, the acid-forming bacteria break down molecules of six atoms of carbon (glucose) into molecules of less atoms of carbon (acids) which are in a more reduced state than glucose. The principal acids produced in this process are acetic acid, propionic acid, butyric acid and ethanol.

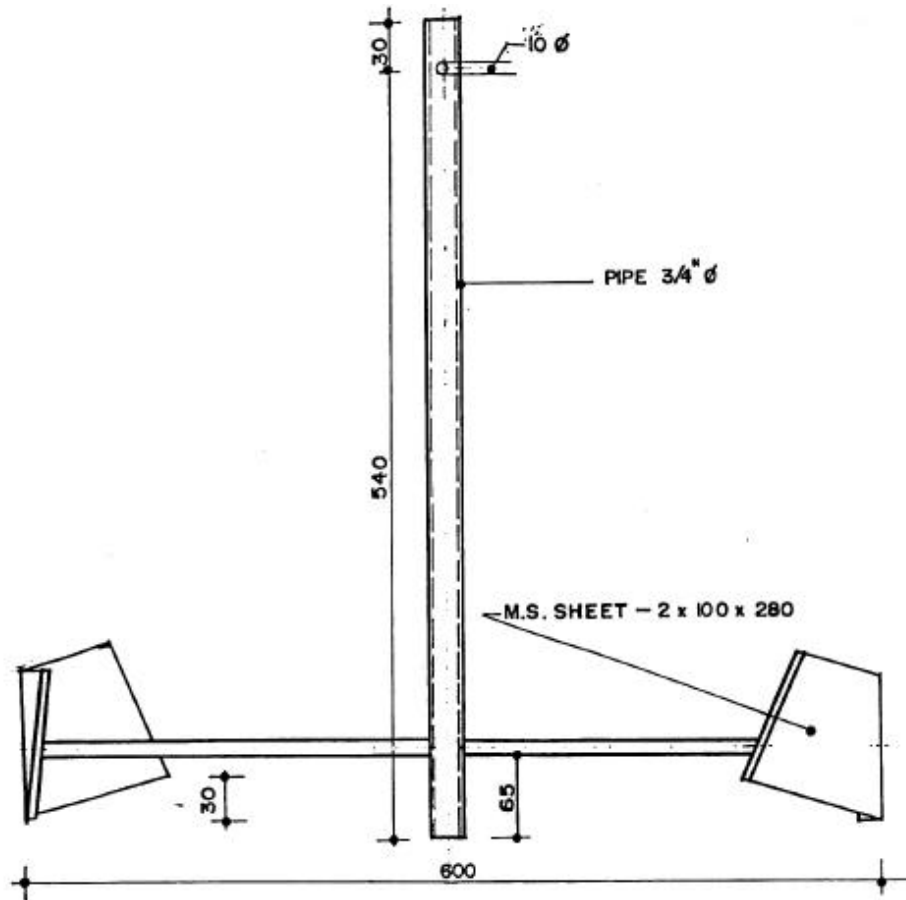

FRONT VIEW

GALVNIZED VER. MIXER MACHINE

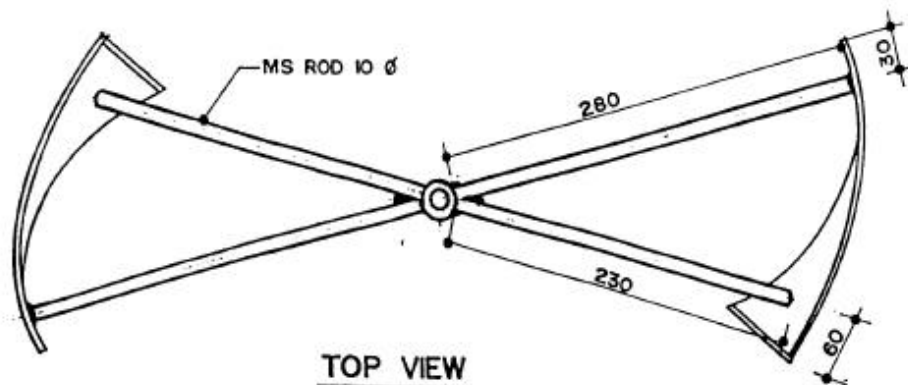

TOP VIEW

FIGURE 1-8 SPECIFICATION OF SLURRY MIXTURE MACHINE

ALL DIMENSIONS ARE IN MM

**Stage 3 Methanization:** The principle acids produced in Stage 2 are processed by methanogenic bacteria to produce methane. The reactions that takes place in the process of methane production is called Methanization and is expressed by the following equations (Karki and Dixit. 1984).

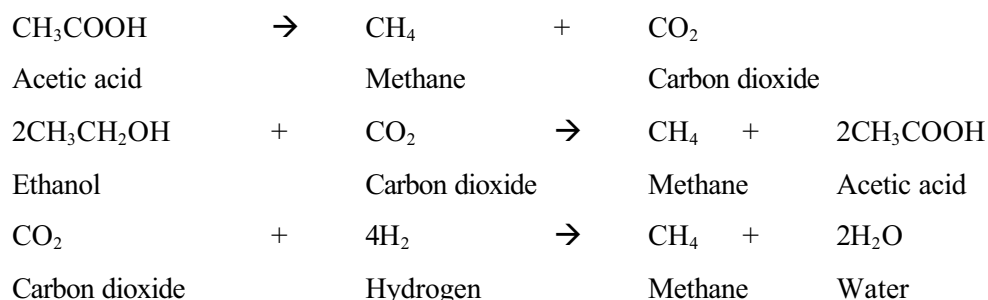

The above equations show that many products, by-products and intermediate products are produced in the process of digestion of inputs in an anaerobic condition before the final product (methane) is produced. Obviously, there are many facilitating and inhibiting factors that play their role in the process. Some of these factors are discussed below.

**pH value :** The optimum biogas production is achieved when the pH value of input mixture in the digester is between 6 and 7. The pH in a biogas digester is also a function of the retention time. In the initial period of fermentation, as large amounts of organic acids are produced by acid forming bacteria, the pH inside the digester can decrease to below 5. This inhibits or even stops the digestion or fermentation process. Methanogenic bacteria are very sensitive to pH and do not thrive below a value of 6.5. Later, as the digestion process continues, concentration of  $\text{NH}_4$  increases due to digestion of nitrogen which can increase the pH value to above 8. When the methane production level is stabilized, the pH range remains buffered between 7.2 to 8.2.

**Temperature:** The methanogens are inactive in extreme high and low temperatures. The optimum temperature is  $35^\circ\text{C}$ . When the ambient temperature goes down to  $10^\circ\text{C}$ , gas production virtually stops. Satisfactory gas production takes place in the mesophilic range, between  $25^\circ$  to  $30^\circ\text{C}$ . Proper insulation of digester helps to increase gas production in the cold season. When the ambient temperature is  $30^\circ\text{C}$  or less, the average temperature within the dome remains about  $4^\circ\text{C}$  above the ambient temperature (Lund, Andersen and Tony-Smith, 1996).

**Loading Rate:** Loading rate is the amount of raw materials fed per unit volume of digester capacity per day. In Nepalese conditions, about 6 kg of dung per  $\text{m}^3$  volume of digester is recommended incase of a cow dung plant (BSP, 1992). If the plant is overfed, acids will accumulate and methane production will be inhibited. Similarly, if the plant is underfed, the gas production will also be low.

**Retention Time:** Retention time (also known as detention time) is the average period that a given quantity of input remains in the digester to be acted upon by the methanogens. hi a cow dung plant, the retention time is calculated by dividing the total volume of the digester by the volume of inputs added daily. Considering the climatic conditions of Nepal, a retention time of 50 to 60 days seems desirable. Thus, a digester should have a volume of 50 to 60 times the slurry added daily. But for a night soil biogas digester, a longer retention time (70-80 days) is needed so that the pathogens present in human faeces are destroyed. The retention time is also dependent on the temperature and upto  $35^\circ\text{C}$ , the higher the temperature, the lower the retention time (Lagrange, 1979).

**Toxicity:** Mineral ions, heavy metals and the detergents are some of the toxic materials that inhibit the normal growth of pathogens in the digester. Small quantity of mineral ions (e.g. sodium, potassium, calcium, magnesium, ammonium and sulphur) also stimulates the growth of bacteria, while very heavy concentration of these ions will have toxic effect. For example, presence of  $\text{NH}_4$  from 50 to 200 mg/l stimulates the growth of microbes, whereas its concentration above 1,500 mg/l produces toxicity.

Similarly, heavy metals such as copper, nickel, chromium, zinc, lead, etc. in small quantities are essential for the growth of bacteria but their higher concentration has toxic effects. Likewise, detergents including soap, antibiotics, organic solvents, etc. inhibit the activities of methane producing bacteria and addition of these substances in the digester should be avoided. Although there is a long list of the substances that produce toxicity on bacterial growth, the inhibiting levels of some of the major ones are given in Table 1.4.

**Table 1.4**  
**Toxic Level of Various Inhibitors**

S. N.	Inhibitors	Inhibiting Concentration
1.	Sulphate (SO <sub>4</sub> <sup>-</sup> )	5,000 ppm
2.	Sodium Chloride or Common salt (NaCl)	40,000 ppm
3.	Nitrate (Calculated as N)	0.05 nig/ml
4.	Copper (Cu <sup>++</sup> )	100 mg/l
5.	Chromium (Cr <sup>+++</sup> )	200 mg/l
6.	Nickel {Ni <sup>+++</sup> }	200 - 500 mg/l
7.	Sodium (Na <sup>+</sup> )	3,500 - 5,500 mg/l
8.	Potassium (K <sup>+</sup> )	2,500 - 4,500 mg/l
9.	Calcium (Ca <sup>++</sup> )	2,500 - 4,500 mg/l
10.	Magnesium (Mg <sup>++</sup> )	1,000 - 1,500 mg/l
11.	Manganese (Mn <sup>++</sup> )	Above 1,500 mg/l

Source: The Biogas Technology in China, BRTC, China (1989)

### 1.2.6 Slurry

This is the residue of inputs that comes out from the outlet after the substrate is acted upon by the methanogenic bacteria in an anaerobic condition inside the digester. After extraction of biogas (energy), the slurry (also known as effluent) comes out of digester as by-product of the anaerobic digestion system. It is an almost pathogen-free stabilized manure that can be used to maintain soil fertility and enhance crop production. Slurry is found in different forms inside the digester as mentioned below:

- a light rather solid fraction, mainly fibrous material, which float on the top forming the scum;
- a very liquid and watery fraction remaining in the middle layer of the digester;
- a viscous fraction below which is the real slurry or sludge; and
- heavy solids, mainly sand and soils that deposit at the bottom.

There is less separation in the slurry if the feed materials are homogenous. Appropriate ratio of urine, water and excrement and intensive mixing before feeding the digester leads to homogeneous slurry.

### 1.2.7 Use of Biogas

Of the outputs of biogas, the gas is valued for its use as a source of energy and the slurry for its fertilizing properties (soil nutrients). Energy content of biogas can also be transformed into various other forms such as mechanical energy (for running machines) and heat energy (for cooking and lighting) depending on the need and availability of the technology. Some of the common uses of biogas are; (a) cooking, (b) lighting, (c) refrigeration, and (d) running internal combustion engine.



### 1.3 Implications of Biogas System

Biogas technology is best suited to convert the organic waste from agriculture, livestock, industries, municipalities and other human activities into energy and manure. The use of energy and manure can lead to better environment, health, and other socio-economic gains is shown in Chart 1.2.

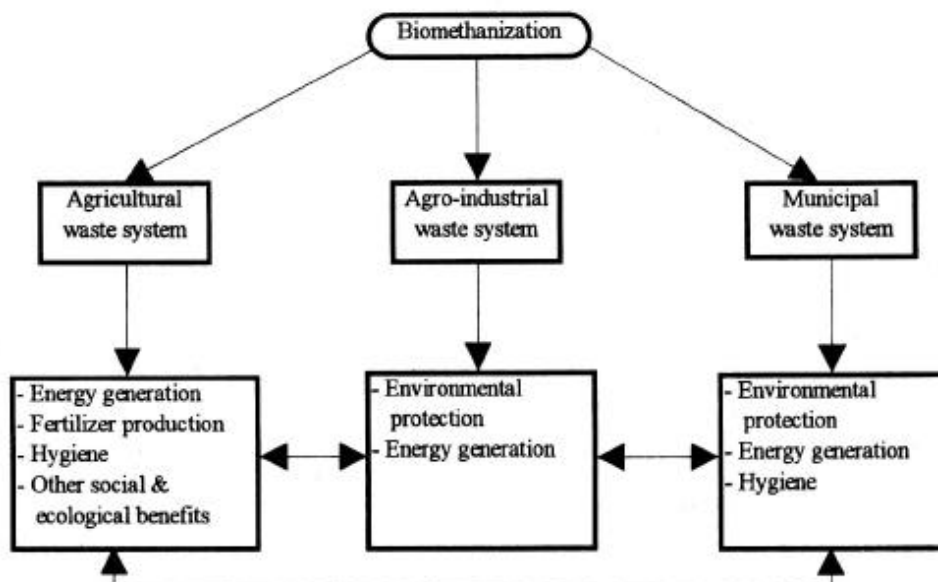

Chart 1.2 Biomethanization Implementation and its Effects

### 1.4 Session Plan

Activity No.	Topic and Area of Discussion	Time (minutes)	Methods of Training	Teaching-Aids
1.	Introduction and highlight of the objectives of the session	3	Lecture	Overhead (O/H) projector, screen and flip chart
2.	Component of a biogas system	20	Lecture	O/H projector, screen and flip chart
3.	Broader implications of biogas system	7	Lecture cum discussion	O/H projector, screen and flip chart
4.	General discussion	20	Discussion	Questions and answers
<b>Total Time</b>		<b>50</b>		

### 1.5 Review Questions

- Prepare a list of different components of a system for biogas generation.
- What are the main functions of a biodigester?
- Can biogas be produced in an open pit?
- What factors need to be considered in selecting a particular design of a biogas plant?
- How could biogas technology be useful for urban population?

- Why is biogas technology viewed more as a technology for rural people?
- What role can biogas technology play in the overall development of Nepal?
- Prepare a list of minimum qualifications that a potential biogas user should have.

## 1.6 References

Alexander, M. (1961) Introduction to Soil Microbiology. John Wiley & Sons, Inc. pp 227-231.

Beteta, T. (1995) Experiences with Plastic Tube Biodigesters in Colombia. Universidad National Agraria, Managua, Nicaragua.

Bioenergy Systems Report : Innovations in Biogas Systems and Technology (1984). Bio-energy Systems and Technology Project of the USAID. "

Biogas and Natural Resources Management (BNRM) Newsletter. Issue No 1 to 51, 1978-1996.

Cortsen, L., M. Lassen and H. K. Nielsen (1995) Small Scale Biogas Digesters in Turiani, Nronga and Amani, Tanzania. University of Aarhus. Denmark.

Flippo, Edward B. (1981) Personnel Management, McGrawHill.

Gunnerson, C. G. and D. V. Stuckey (1986) Integrated Resource Recovery-Anaerobic Digestion-Principles and Practices for Biogas systems. World Bank Technical Paper No. 49.

Karki, A. B. and K. Dixit (1984) Biogas Fieldbook. Sahayogi Press, Kathmandu, Nepal.

Karki, A. B., K. M. Gautam and A. Karki (1994) Biogas Installation from Elephant Dung at Machan Wildlife Resort, Chitwan, Nepal. Biogas Newsletter, Issue No. 45.

Lagrange, B. (1979) Biomethane 2: Principles - Techniques Utilization. EDISUD, La Caiade, 13100

Aix-en-Provence, France-Lund, M. S., S. S. Andersen and M. Torry-Smith (1996) Building of a Flexibility Bag Biogas Digester

in Tanzania. Student Report. Technical University of Denmark, Copenhagen.

Ni Ji-Qin and E. J. Nyns (1993) Biomethanization : A Developing Technology in Latin America- Catholic University of Louvain, Belgium, pp 67-68.

Optner, S. L. (1997) System Analysis. Penguin Books Ltd, Harmondsworth, Middlesex, England.

Sathianathan, M. A. (1975) Biogas Achievements and Challenges. Association of Voluntary Agencies of Rural Development, New Delhi, India.

Singh, J. B, R. Myles and A. Dhussa (1987) Manual on Deenbandhu Biogas Plant. Tata McGraw Hill Publishing Company Limited, India.

The Biogas Technology in China (1989) Chengdu Biogas Research Institute, Chengdu, China.

Updated Guidebook on Biogas Development-Energy Resources Development Series (1984), No. 27. United Nations. New York, USA.

Yadava. L. S. and P. R. Hcsc (1981) The Development and Use of Biogas Technology in Rural Areas of Asia (A Status Report 1981). Improving Soil Fertility through Organic Recycling. FAO/UNDP Regional Project RAS/75/004, Project Field Document No. 10.

### **1.7 Further Reading Materials**

FAO, Kathmandu (1996) Report on the Meeting for the Development of a National Biogas Policy Framework and Celebration of the 10,000th Biogas Plant Construction with BSP Support. FAO. Kathmandu, 7 February 1996.

Gautam, K. M. (1996) Country Paper on Biogas in Nepal Paper presented at International Conference on Biomass Energy Systems organized by Tata Energy Research Institute, British Council Division and British High Commission. New Delhi, India. 26-27 February 1996.

Karki, A. B. (1985) Construction of Biodigesters at Farmers' Level. FAO Office for Latin America and the Caribbean. Santiago. Chile.

Karki, A. B. (1984) Biogas Training Course for Rural Development Workers of Kingdom of Lesotho. FAO, Rome, Italy

Karki, A B, K M Gautam and A. Karki (1994) Biogas for Sustainable Development in Nepal Paper presented at " Second International Conference on Science and Technology for Poverty Alleviation organized by Royal Nepal Academy for Science and Technology (RONAST), Kathmandu, Nepal. 8-11 June 1994.'

The Eighth Five Year Plan 1992-1997. National Planning Commission. Nepal  
UNDP/ESCAP/FAO/CHINA (1983) Biogas Technology. The Asian-Pacific Regional Biogas Research and Training Centre, Chengdu, China.

United Mission to Nepal (1985) Biogas : Challenges and Experience from Nepal. Vol. I. United Mission to Nepal (1985) Biogas : Challenges and Experience from Nepal. Vol. II.